

INSTALACION FIJA, CANTO RODADO, 120 tn/h

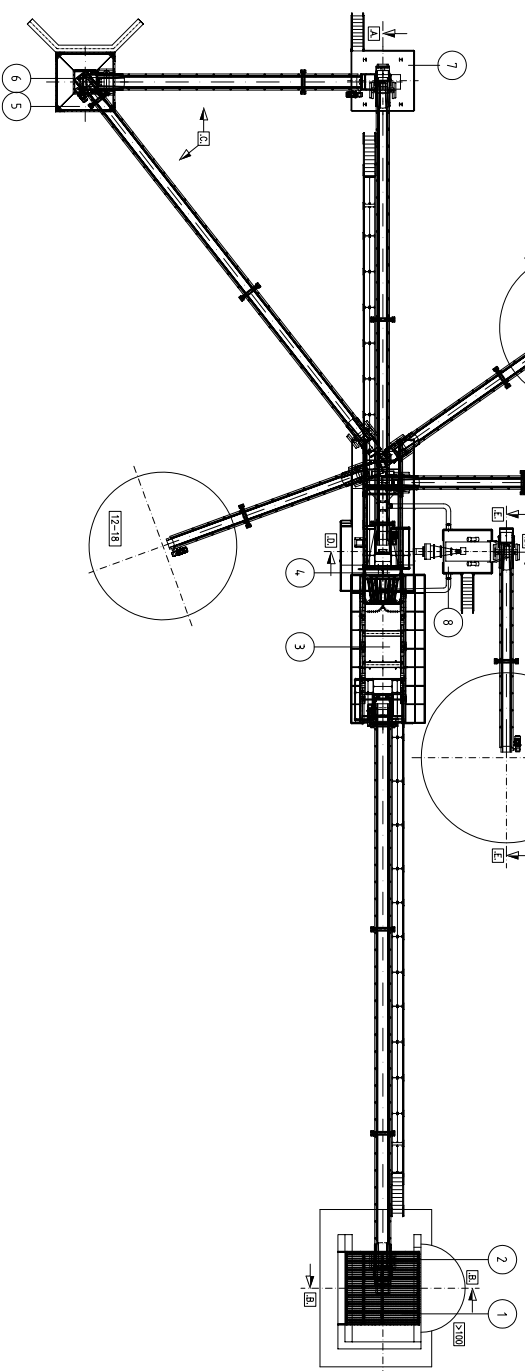
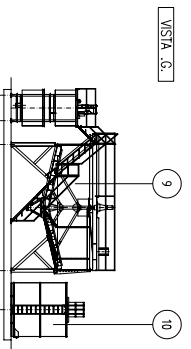
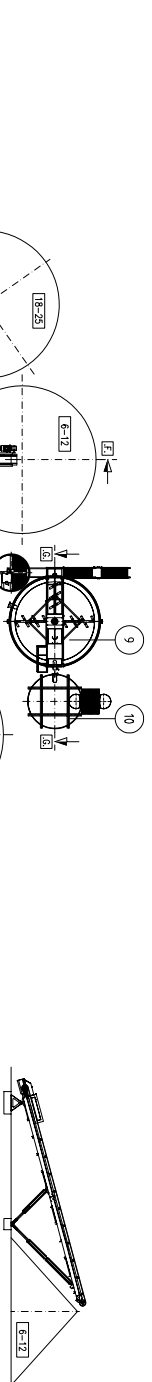
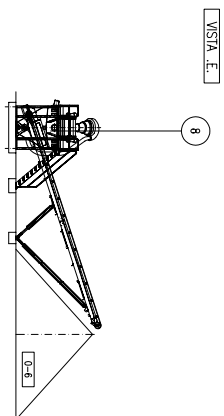
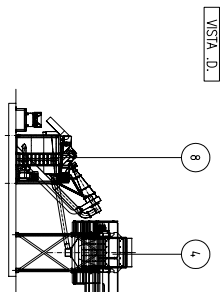
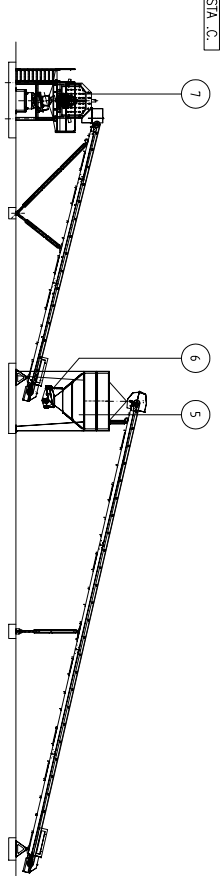
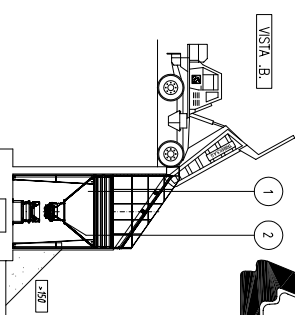
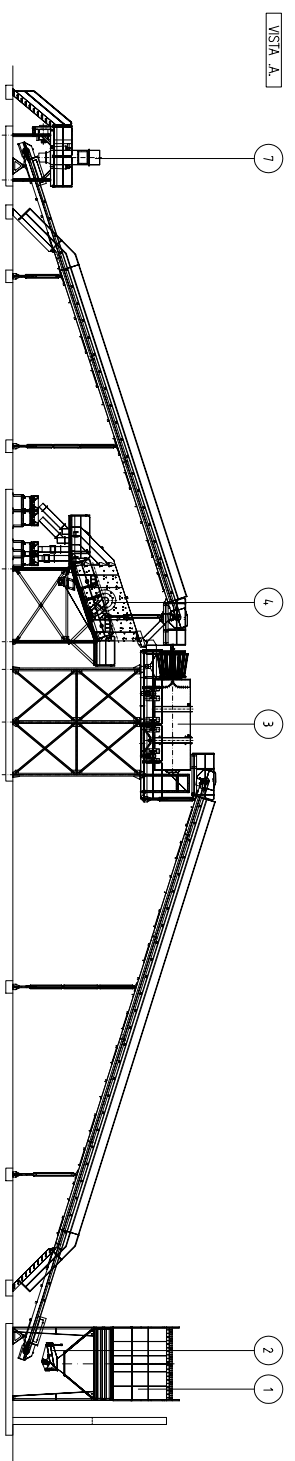

REF.	DESCRIPCIÓN	CANTIDAD
1	TOLVA 30 m ³	1
2	ALIMENTADOR VIBRANTE AVT-160	1
3	TROMEL DE LAVADO TLT-80	1
4	CRIBA VIBRANTE CVT-154S-IV	1
5	TOLVA 20 m ³	1
6	ALIMENTADOR VIBRANTE AVT-120	1
7	MOLINO IMPACTOR SECUNDARIO TMI-2-S	1
8	EQUIPO DE LAVADO ELT-50	1
9	DECANTADOR DE Lodos DLT-175	1
10	DEPOSITO DE AGUAS CLARAS	1
	CINTAS TRANSPORTADORAS	8